



High-Pressure Water Mist



Industry leaders in domestic and residential fire suppression.

Manufactured in Britain, Installed Worldwide.

The iCO® High-Pressure Water Mist System has been precision-engineered for residential fire protection, delivering rapid and effective fire suppression.

Designed to integrate discreetly into residential environments, the iCO® High-Pressure Water Mist System provides reliable life safety performance without compromising aesthetics or practicality.

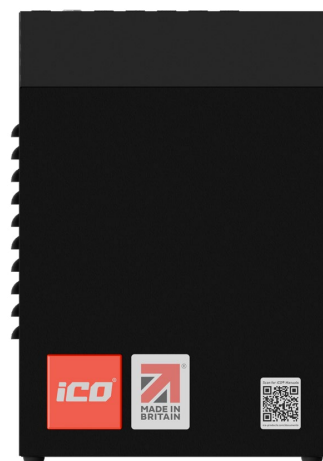

Patents granted: UK, USA, Australia, Europe

Patents pending: UAE

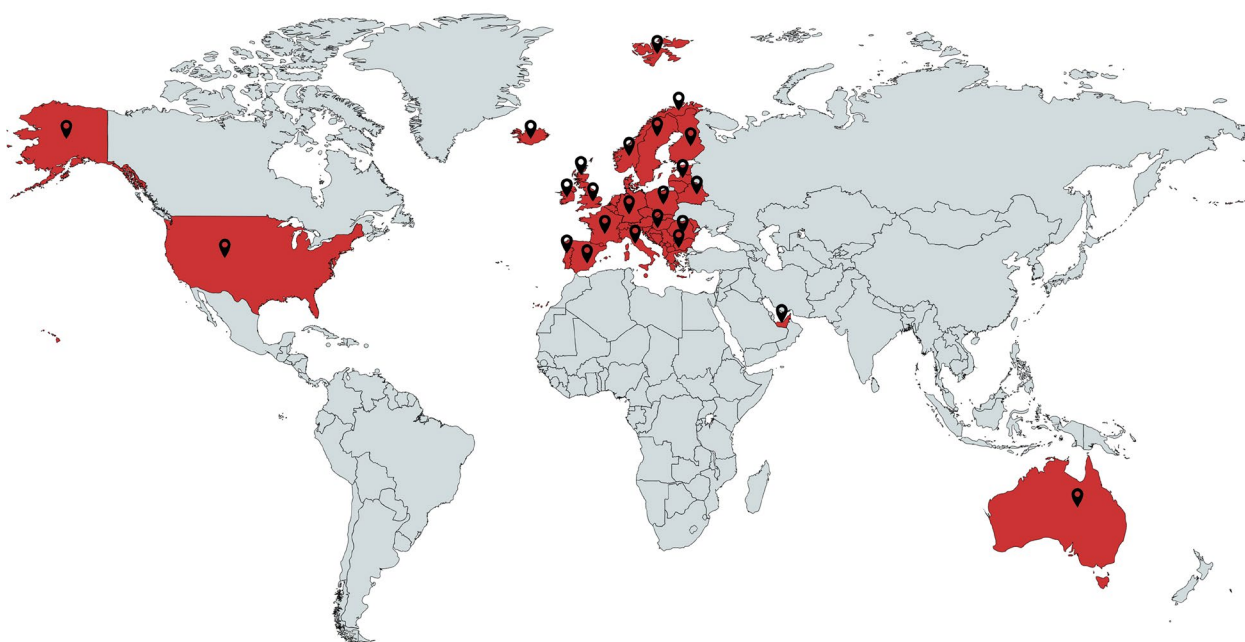

United Kingdom • Europe • Australia • USA • United Arab Emirates

Discreet and Compact Design.

The iCO® water mist nozzles sit at just 3mm below the ceiling and are the most discreet on the market.

The compact iCO® pump connects directly to the water mains using flexible piping and easy-fit fittings, making the system highly adaptable, cost efficient and easy to install. There is no need to upgrade the water mains or fit an expensive water tank.



High-Pressure Water Mist

iCO® designs and manufactures industry-leading fire suppression products. Our high-pressure water mist system is Made in Britain™ and independently fire performance tested at an ISO/IEC 17025-accredited fire research facility.

iCO® HIGH-PRESSURE NOZZLES

The iCO® easy fit nozzles are extremely low profile, sitting just 3mm below the ceiling and can be colour matched to any colour using the RAL colour code system.

Patents granted: United Kingdom, USA, Australia, Europe

Patents pending: UAE



72mm x 19mm

Dimensions

200g

Weight

57 °C

Bulb Specification

16m²

Fire Suppression

White

Standard Colour

Stainless 316

Material

Torsion Springs

Fixing method

iCO® PUMP

The sleek, compact iCO® pump unit connects directly to the existing mains water supply: using an impressive 12 litres per minute for rapid and effective fire suppression.

The smart-enabled system includes an on-board monthly self test and manual test facility with real time monitoring and alerts.

The control board monitors the pump and is equipped with fire and fault N/O and N/C relays for use with third party equipment (e.g. alarms and fire panels).



342mm² x 495mm

Dimensions

24kg

Weight

240V

Voltage Rating

13A

Current Rating

12lpm @ 1 bar

Minimum Water Requirement

1/2" BSP

Inlet Connection

3/8" BSP 60 °C Cone

Outlet Connection

Floor or wall

Mounting



iCO[®]

High-Pressure Water Mist Versus Traditional Sprinklers.

Unlike traditional sprinkler systems originally developed for commercial environments, the iCO[®] High-Pressure Water Mist System has been engineered specifically for modern residential fire protection.

Using ultra-fine high-pressure water droplets, the system rapidly cools the fire, reduces oxygen around the flame and helps prevent re-ignition, delivering fast and effective fire suppression with up to 80% less water than conventional sprinklers.

Designed to provide intelligent, targeted fire protection, the iCO[®] system combines advanced performance, reduced water usage and discreet residential integration in a next-generation fire suppression solution.

High-Pressure Water Mist

Key features

Water Requirement

The iCO® system is designed to operate using the lowest flow and pressure possible (12l/min @ 1 bar).

Rapid response

The iCO® water mist system quickly eliminates all three elements that cause a fire (heat, fuel and oxygen).

Reliable activation

The iCO® nozzles are highly reliable and can be activated by a double knock trigger (heat and smoke) as an option to reduce the risk of false activation.

Localised suppression

Only the nozzle nearest the fire will operate: protecting other areas of the property from water damage.

Minimal water damage

On average iCO® uses 80% less water than traditional sprinklers, minimising water damage when activated.

Low maintenance

The iCO® pump has a removable cover so that the internal components can be serviced on-site if needed.

Easy installation

iCO® simple design and flexible hoses make installation a breeze when compared to conventional sprinkler systems.

Environmentally friendly

The iCO® system only uses water from the mains when needed: saving vast amounts of water.

Cost efficient

The iCO® system connects directly to the current water supply: no need to upgrade the mains or install a tank.

Discreet and compact design

The iCO® pump unit will fit in most kitchen cabinets. Our nozzles are the most discreet on the market and can be colour matched to any colour.

Highly adaptable

iCO® adaptability means the system can be installed in almost any residential or domestic category project.

Automated self testing

The iCO® pump unit automatically tests itself once a month to ensure the unit is functioning correctly. Unlike other systems no water is used and no drain is required.



One solution, multiple applications.

The iCO® system can be installed in almost any residential or domestic property.

iCO® is an ideal solution for private homes, heritage or listed buildings, new-build properties, apartments, care homes, student accommodation, hotels, industrial kitchens and HMOs (houses in multiple occupancy) where the risk of fire is greater.

Passive fire protection is often used to pass building regulations; such as internal fire doors, travel distances to exits and fire-retardant materials within the fabric of the building.

A growing number of forward-thinking architects and developers are specifying the iCO® system in their designs to reduce the passive requirements needed to meet regulations: allowing more flexibility and freedom of design.





iCO® Misting Nozzles
Technical Data





Technical Data - iCO® Misting Nozzles

Part No:	PU002-02
Dimensions:	Ø72mm x 19mm
Weight:	200g
K Factor:	1.71
Temperature Rating:	57°C
Max Pressure:	1020 psi (70 bar)
Minimum Operating Pressure:	40 Bar
Response Type:	Fast (Residential)
Occupancy Type:	Domestic
Connection Size:	3/8" BSP
Minimum Spacing:	2m (6.5ft)
Maximum Spacing:	4m x 4m (13.2 x 13.2ft)
Colour:	White as standard. Other colours available.
Material:	316 Stainless Steel
Fixing method:	Torsion Springs

ACCREDITATIONS

iCO® is ISO 9001 certified for the design, manufacture, testing and supply of water mist fire suppression products. Our systems are developed and tested in line with recognised water mist fire-safety principles and applicable international standards.

All of our fire suppression products are Made in Britain and independently tested to the highest performance and safety standards to protect your home in the event of a fire.

iCO Products® is a member of both the Fire Protection Association (FPA) and the Fire Industry Association. The iCO® patented technology has been independently tested by Warringtonfire and the Baltic Fire Laboratory, both ISO/IEC 17025-accredited fire-testing laboratories, providing independent validation of fire performance under controlled test conditions.



DIMENSIONS (MM)

The iCO® easy fit nozzles are extremely low profile. Sitting just 3mm below the ceiling they are the most discreet misting water mist nozzles on the market.

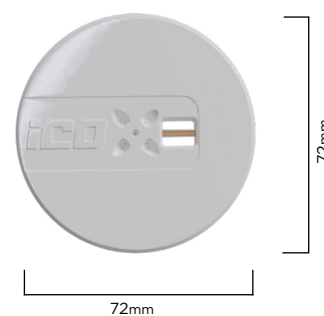
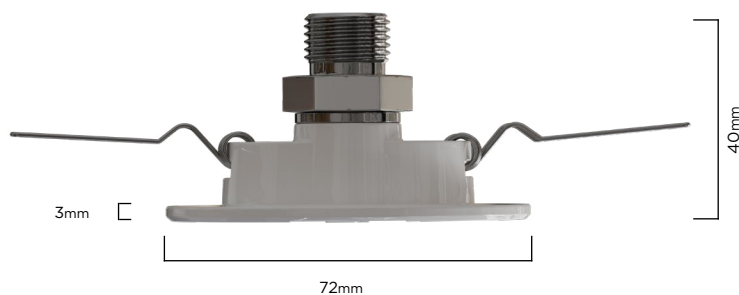

INSTALLATION

iCO® water mist and fire suppression products must be designed, installed, commissioned and maintained by an industry approved fire suppression company.

To find a local installer, visit ico-products.com/find-installer



KEY BENEFITS



HIGHLY ADAPTABLE



DISCREET DESIGN



RAPID RESPONSE



ECONOMICAL



REAL-TIME ALERTS



SIGNIFICANT SAVINGS



EASY INSTALLATION



HIGH PERFORMANCE



MINIMAL DAMAGE



LOW MAINTENANCE

KEY FEATURES

Excellent Quality Assured

iCO[®] is independently tested in line with automatic water fire suppression systems standards.

Discreet Nozzle Design

The iCO[®] easy fit nozzles are extremely low profile and can be colour matched to any colour using the RAL colour code system.

Rapid Response

The iCO[®] water mist system quickly eliminates all three elements that cause a fire (heat, fuel and oxygen).

Reliable Activation

iCO[®] nozzles are highly reliable and can be activated by a double knock trigger: as an option to reduce the risk of false activation.

Localised Suppression

Only the nozzle nearest the fire will operate: protecting other areas of the property from water damage.

Minimal Water Damage

On average iCO[®] uses 80% less water than traditional sprinklers: minimising water damage whilst providing the same performance.

Minimal Smoke

iCO[®] uses very small droplets of water as a fine mist: quickly reducing the harmful smoke and toxic gases caused by a fire.

Environmentally Friendly

The iCO[®] system only uses water from the mains when needed: saving vast amounts of water.

Outstanding Durability

The iCO[®] nozzles are made from stainless steel and capable of withstanding extreme temperatures in the event of a fire.

Highly Adaptable

iCO[®] adaptability means the system can be installed in almost any residential or domestic category project.

Easy Installation

iCO[®] simple design and flexible hoses make installation a breeze when compared to conventional sprinkler systems.

Ceiling Mounted Nozzles

The iCO[®] misting nozzles are situated in the ceiling: attacking the fire from above without obstruction from furniture.

Battery Backup

Battery back-up to provide audible alarm in the event of power loss or system failure.

External Power Out

12V power out for powering 3rd party equipment such as GSM alarm diallers for remote monitoring or external relays.

Additional Relay Connections

iCO[®] provides 2 fault & 2 alarm relays as standard for connection to 3rd party equipment such as fire alarms and AOV's.

Real Time Monitoring and Alerts

iCO[®] System GSM Monitoring provides real time alerts to your smart phone in case of emergency or fault.

Technical Data - iCO® Misting Nozzles

INSTALLATION

NOZZLE SPACING: FLAT CEILING

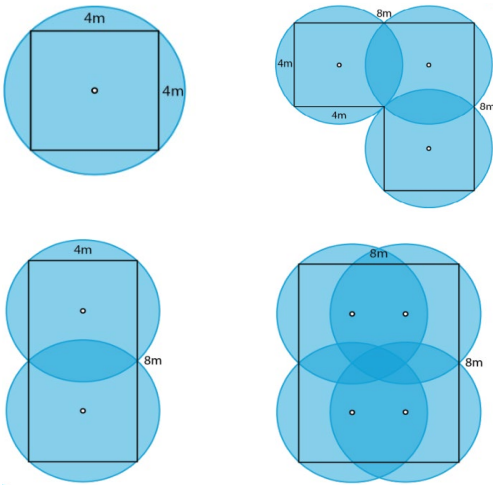

Installation Notes:

- ¹ 4x4m Grid (16m²)
- ² Max 2m from wall
- ³ 2m minimum distance between nozzles

NOZZLE ORIENTATION

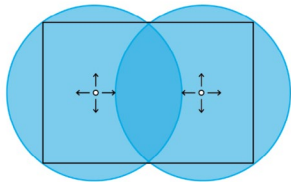

Installation Notes:

- ¹ The preferred nozzle outlet orientation is perpendicular to the walls of a room.
- ² Nozzles should be positioned away from obstructions to allow a 140° spray pattern.

DISTANCE FROM OBSTRUCTIONS

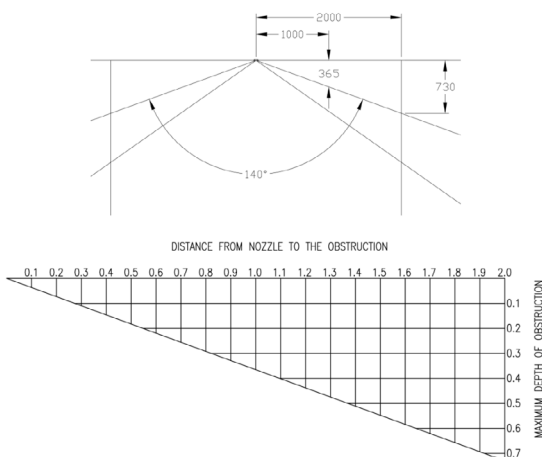

NOZZLE SPACING: SLOPED CEILING

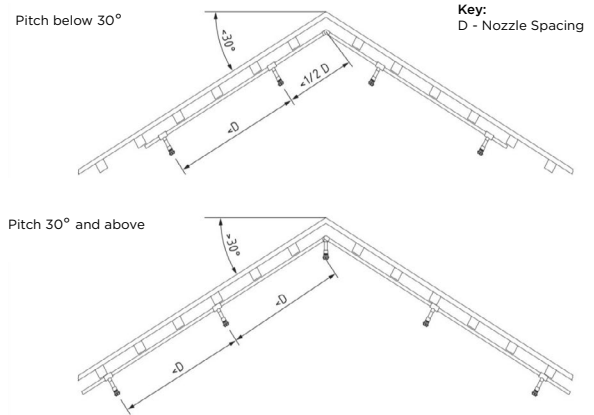

Installation Notes:

- ¹ When installing iCO® misting nozzles on sloped ceilings, the position of the nozzle should be determined by the pitch of the ceiling.
- ² Where the pitch is below 30° iCO® nozzles should be mounted at standard spacing when measured in line with the pitch of the ceiling.
- ³ Where the pitch is 30° and above, the first row of iCO® nozzles should be mounted within 300mm radially from the apex of the ceiling.
- ⁴ All nozzles should be mounted perpendicular to the ceiling as shown below.

NOZZLE ORIENTATION: PENDANT LIGHT FITTINGS

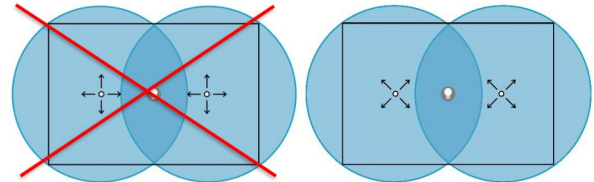

Installation Notes:

- ¹ Nozzle spray angles should not be directed at pendant light fittings.
- ² The spray direction can be rotated 45° to spray into the corners of a room to avoid pendant light fittings. Nozzles should be at least 500mm away from a pendant light fitting.

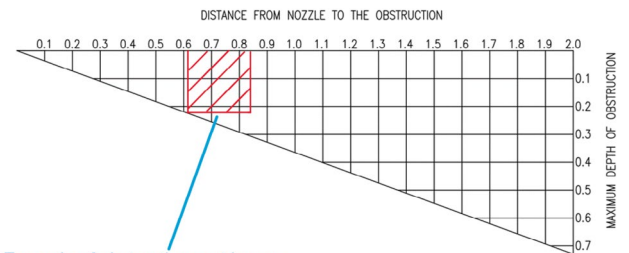

Example of obstruction matrix use.

If obstruction fits wholly inside matrix, nozzle positioning is unaffected.

Maintenance and Storage Notes:

- ¹ The nozzle should be maintained in accordance with BS8458
- ² Minimum/Maximum ambient temperature 4°C/40°C



ico® Pump Unit V2
Technical Data





Technical Data - iCO® Pump Unit V2

Part No:	PU001-00
Dimensions:	342mm (W)x 342mm (D) x 495mm
Clearance requirement:	100mm of clear space required around on each side for ventilation
Voltage rating:	240V
Current rating:	13A
Power Supply Connection:	Dedicated 16A fused supply from the NON RCD side of the board. Fire rated cable required
Inlet connection:	1/2" BSP
Outlet connection:	3/8" BSP 60° Cone
Water requirement:	12 lpm @ 1 bar Minimum
Pump run sound pressure level:	79db @ 1 m
Pump run Flow switch:	0.5lpm
Weight:	24kg
Serviceability Access:	Removable front cover with security screws
Internal Components:	Corrosion resistant brass and stainless steel
Mounting:	Floor or wall mount
Standing Pressure:	Mains water pressure 1-10bar
Running Pressure:	Adjustable 10-100bar
Mains low pressure monitoring:	Set at 0.5 bar
Mains water over pressure protection:	Pressure relief set at 20bar
Pump run time:	10min or 30min (adjustable with pump and actuated ball valve shut off)
Operation:	Wet type or pre-action linked to smoke detection
Self-test:	Monthly self-test
Heat protection:	Thermal fuse set at 100°C
Fire relay:	2x NO / NC volt free 30vDC 1 A
Fault relay:	2x NO / NC volt free 30vDC 1 A
Priority demand valve output:	12v 1A
Power out:	12v 1A
Power monitoring:	Battery backed up audible alarm for fault monitoring
Battery monitoring:	Check every 8mins if battery is detached
System indication:	Internal LCD display
Control valve:	Integral isolation valve, drain valve & pressure gauge
Strainer:	Internal 500 micron filter
IP Rating:	IP53
Manual controls:	Internal and optional external manual start and stop button

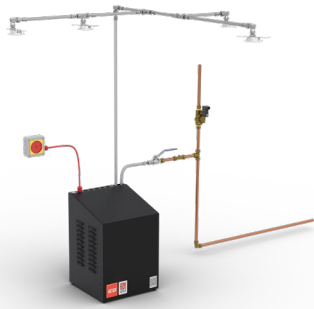

Typical domestic category installation.



Typical residential category installation.

NOTE: All images in this document are for illustration purposes only.

KEY BENEFITS



EASY INSTALLATION



**USES JUST 12L/MIN
AT 1 BAR OF
PRESSURE**



**NO STORED WATER
NEEDED**



**80% LESS WATER
THAN STANDARD
SPRINKLERS**



FULLY COMPLIANT

KEY FEATURES

Excellent Quality Assured

iCO® is independently tested in line with automatic water fire suppression system standards.

Neat, Compact Design

All system components are integrated and housed within the iCO® pump unit: no untidy valves or hoses.

Automated Self-Test

The iCO® pump unit automatically tests itself once a month to ensure the unit is functioning correctly.

Removable Cover

The iCO® pump unit has a removable cover allowing easy access for servicing and maintenance.

Outstanding Durability

The iCO® pump unit is comprised of steel: protecting it from fire and mechanical damage.

Wall or Floor Mounted

The iCO® pump will fit in most kitchen cupboards or can be wall mounted if preferred.

Adjustable Run Time

The iCO® pump can be adjusted to suit a 30min (Residential) or 10min (Domestic) application, depending on the need.

Adjustable Run Pressure

The iCO® pump can be adjusted from 10 - 100bar to suit the particular building or application.

Actuated Ball Valve

iCO® has an integrated actuated ball valve to shut off the water and power supply following elapse of the selected run time.

External Power Out

12V power out for powering 3rd party equipment such as GSM alarm diallers for remote monitoring or external relays.

Battery Backup

Battery backup to provide audible alarm in the event of power loss or system failure.

LCD Display

An internal LCD display is provided on the control & monitoring board to indicate the status of the system.

Thermal Fuse

A thermal fuse has been provided on the control & monitoring board to cut power if the temperature exceeds 100°C.

Manual Start/Stop Button

The iCO® pump unit has a connection point for an (optional) manual start/stop button.

Double Knock Activation

The iCO® nozzles are activated by a double knock trigger (heat/smoke): significantly reducing the risk of false activation.

Additional Relay Connections

iCO® provides 2 fault & 2 alarm relays as standard for connection to 3rd party equipment such as fire alarms and AOV's.

Drip Tray with Float Switch

The iCO® float switch will close the actuated ball valve in the event of a leak: shutting off the water supply to avoid damage.



Technical Data - iCO® Pump Unit V2

TECHNICAL PUMP SCHEMATIC (DOMESTIC)

Private homes, heritage or listed buildings and new-build properties.

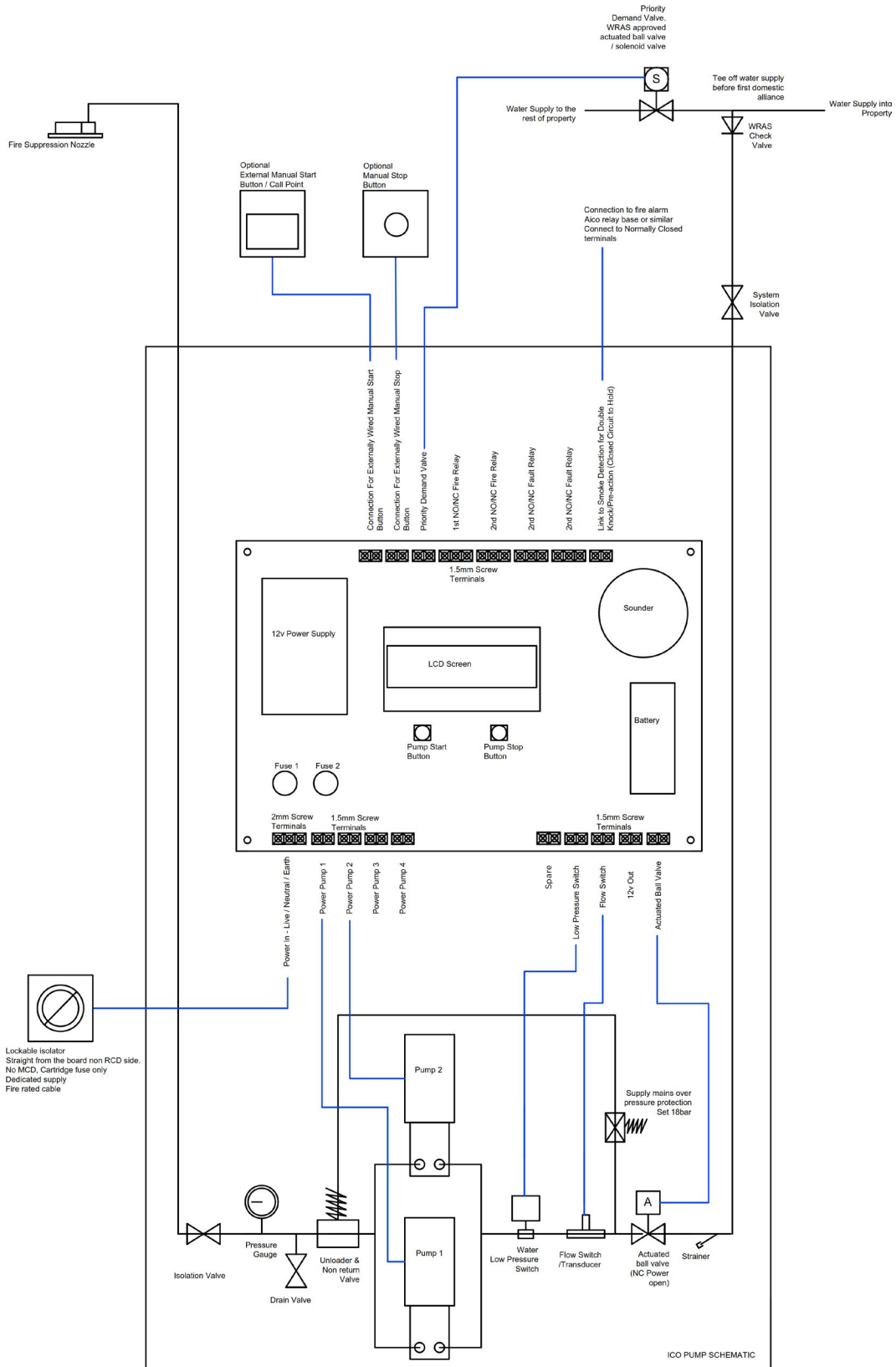



Technical Data - iCO® Pump Unit V2

CONTROL & MONITORING BOARD

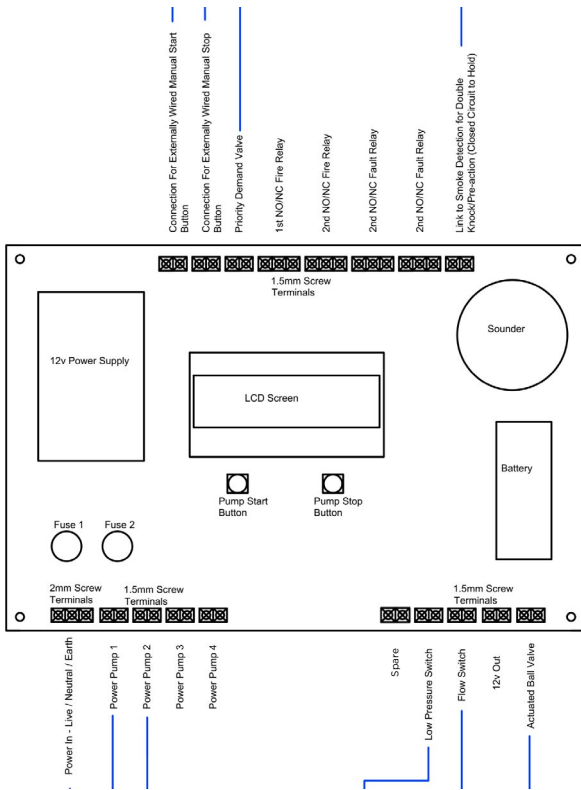

DIMENSIONS (MM)

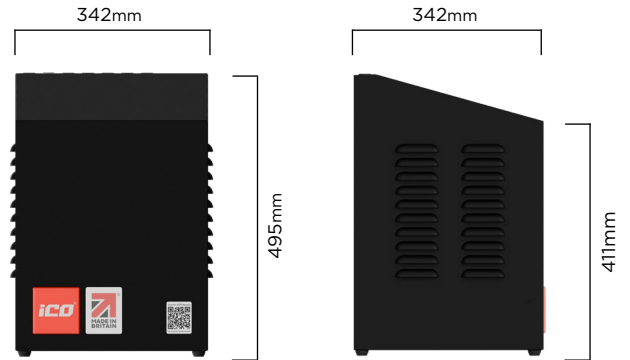

ACCREDITATIONS

iCO® is ISO 9001 certified for the design, manufacture, testing and supply of water mist fire suppression products. Our systems are developed and tested in line with recognised water mist fire-safety principles and applicable international standards.

All of our fire suppression products are Made in Britain and independently tested to the highest performance and safety standards to protect your home in the event of a fire.

iCO Products® is a member of both the Fire Protection Association (FPA) and the Fire Industry Association. The iCO® patented technology has been independently tested by Warringtonfire and the Baltic Fire Laboratory, both ISO/IEC 17025-accredited fire-testing laboratories, providing independent validation of fire performance under controlled test conditions.



WALL MOUNT DETAILS

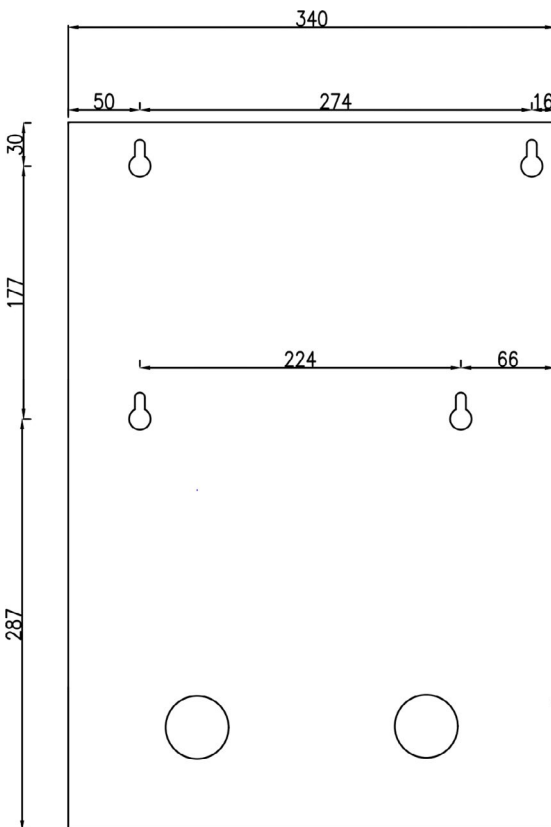

INSTALLATION

iCO® water mist and fire suppression products must be designed, installed, commissioned and maintained by an industry approved fire suppression company.

To find a local installer, visit ico-products.com/find-installer/

A smarter and safer means to protecting lives and property from fire.

iCO Products is LPCB ISO 9001 accredited for the design, manufacture, assembly and testing of residential fire suppression products.

Our patented fire suppression products are manufactured in the UK and sold through a network of accredited installers throughout the UK.

Contact us

@ enquiries@ico-products.com

🖱️ ico-products.com

📌 [@ico-products](#)

📍 iCO Products Ltd
Unit 9 - Cordwallis Business Park
Clivemont Road
Maidenhead
Berkshire SL6 7BU

iCO Products is a member of the Fire Industry Association and an ISO 9001 registered company. We reserve the right to update or modify any information. All values, information, images and illustrations in this brochure, data sheets and all other publications are exemplary and are subject to on-going changes and updates.

